

Specification Sheet

TM3 - TM4 - TM6

Cold Water Turbine Meter 3", 4", and 6"

Features

- Meets or exceeds AWWA C701 Class II accuracy
- Remote ready, includes pit pulse
- Rated to 120°F and 200 psi
- Large numbers for easy reading
- Glass lens resists scratching
- Epoxy coated Cast Iron casing
- 1-year new meter accuracy warranty/ 5-year standard warranty for casing, register, and accuracy (AWWA C701)
- 1 pulse = 100 USG or 10 CF (std)



Application

For use in measurement of potable cold water in commercial and industrial applications where flow is in one direction only. Ideal for high volume applications where space is cramped.

Main Casing

The turbine main casing is made of Cast Iron with epoxy coating.

Register

The combined gear and register unit is fully sealed with a straight odometer for visual reading of billable units as well as high-precision pointers for accurate testing by governing agencies. Both the register and pulse unit are pit rated to IP68 (NEMA 6). The serial number is clearly marked.

Measuring Chamber

The measuring chamber and turbine element are constructed from durable engineered plastics and the meter has inlet straightening vanes along with stainless steel spindles for superior longevity.

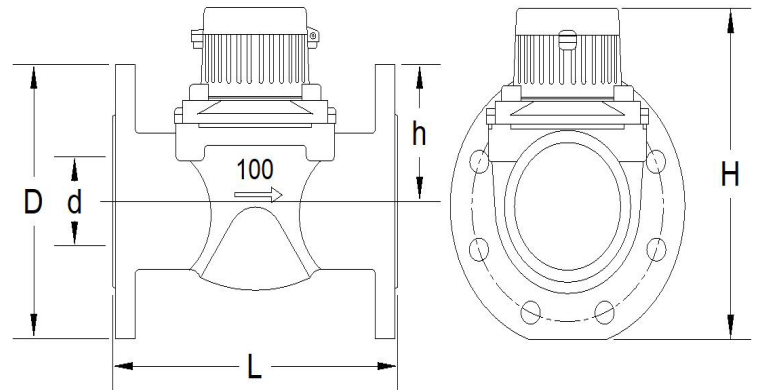

Dimensions

Model # - Meter Size	d	L	D	H	h	D/2
TM3 - 3" (80)	3.15	8.9	8	9.8	6.1	4
TM4 - 4" (100)	3.9	9.8	8.7	10.2	6.1	4.35
TM6- 6" (150)	5.9	11.8	11.125	12.4	7.2	5.56

ALL DIMENSIONS ARE IN INCHES



FOR ORDERS & INQUIRIES:
877-863-8377

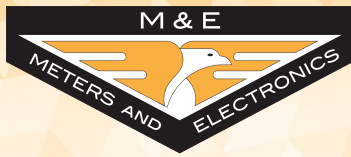

Specification Sheet

TM3H - TM4H - TM6H

Hot Water Turbine Meter 3", 4", and 6"

Installation

It is highly recommended that a Z-plate strainer be used upstream of the meter for protection to the turbine impeller and to reduce effects of turbulence. Industry Standards recommend horizontal installation with 10 pipe diameters upstream of the meter (if a strainer is not used) and 5 pipe diameters downstream. The lack of a strainer may void the warranty of the Turbine meter.

LF bronze companion flanges are available for all sizes.

Model #	TM3	TM4	TM6
Meter Size	3"	4"	6"
Normal Operating Range +/- 1.5% (GPM; CFM)	4-650 (0.53-86.9)	4.8-800 (0.64-106.9)	9.6-1600 (1.28-213.9)
Low Flow (GPM; CFM)	2.5 (0.33)	3 (0.40)	6 (0.80)
Maximum Continuous (GPM; CFM)	650 (86.9)	800 (106.9)	1600 (213.9)
Maximum Intermittent (GPM; CFM)	812 (108.5)	1000 (133.7)	2000 (267.4)
Maximum Pressure (PSI)	200	200	200
Maximum Temperature (F)	122	122	122
Length (in)	8.9	9.8	11.8
Overall Height (in)	9.8	10.2	12.4
Height, bottom to center line (in)	4	4.35	5.56
Width (in)	8	8.7	11.125
Weight (lbs)	29	33	69
Flange Holes (Round flange)	4	8	8
Register Capacity (millions USG; millions CF)	1000 (100)	1000 (100)	1000 (100)



FOR ORDERS & INQUIRIES:
877-863-8377